

260530
310212
161110

← tav. 3

341527

260312
331835
411002

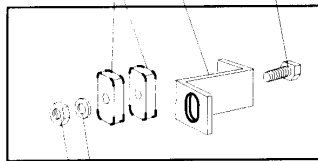

260502
260418

260219
180624
200497

351310

390170
322117
321928
260224

331208

351314

2 - Hood/Tank

CODE	DESCRIPTION
160811	WASHER F2 18X8.5X1 ALGOF
161110	BACK COVER S90-C85-140
180624	DOOR GUIDE C95-155-C165
190637	GUIDE FOR DOOR "C"
190638	ROLLER FOR "C" DOOR GUIDE
200497	GASKET FOR DOOR GUIDE C85-C140
260113	STAINL.ST.TE SCREW 8X20 A2 UNI
260219	STAINL.ST TCP SCREW 6X35 A2 UN
260224	TB-SCREW 6X15 B23-10-11-12
260312	SCREW TSP 4X16
260418	SELF-LOCKING NUT M4
260502	S/S FLAT WASHER D.4
260530	STAINL.ST WASHER 7X22X2
310212	BLIND NUT M6 BLACK NYLON
321928	PLATE F.GUIDE C140
322117	RACK GUIDE C95-C155
331208	ST.STEEL FOOT
331835	BRACKET F.MAGNET C165
341527	INSULATED HOOD FOR C95-155-165
351310	LEFT PANEL C95-C155
351314	RIGHT PANEL C95-C155
390170	BACK PANEL
411002	PERMANENT MAGNET 24X12

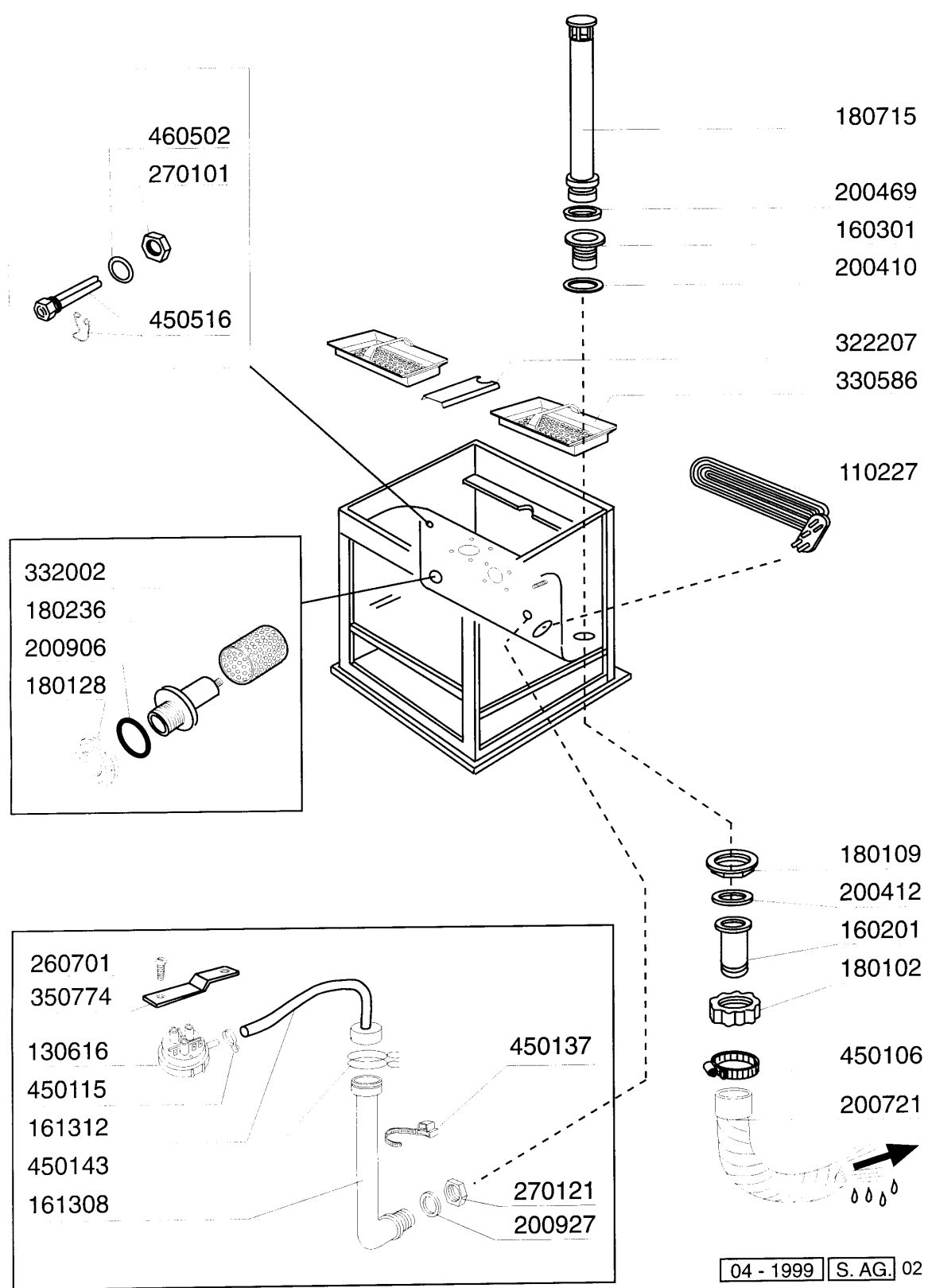

04 - 1999 | S. AG. | 02

3 - Tank

CODE	DESCRIPTION
110227	HEAT. ELEMENT 3000W 230/400V
130616	PRESSURE SWITCH 190/80 FOR C95
160201	ELBOW F.TANK INLET MOPLN
160301	DRAIN OUTLET 1"1/2 C-S-N
161308	AIR CHAMBER C95-155
161312	HOSE FOR PRESSURE SWITCH C95-1
180102	DRAIN PIPE NUT 1"1/2 F45-55
180109	LOCK NUT 1 1/2"
180128	RING NUT 65,4 C140 C85
180236	PUMP SUCTION FOR AC-ACR-C155
180715	OVERFLOW PIPE C95-C155-C165
200410	DRAIN OUTL.WASH.1 1/2"65X47X2
200412	GASKET DRAIN 11/2" 45X33X3
200469	STAND PIPE O RING 45X35,5X7
200721	DRAIN HOSE 28X35 2MT.
200906	GASKET D.92X66X2
200927	GASKET FOR AIR TRAP
260701	SCREW 3,5X9,5
270101	HEXAGON LOCK NUT 1/2"
270121	NUT FOR AIR TRAP
322207	CENTRAL SUPPORT FOR FILTERS C1
330586	TANK FILTER C95-C155-C165
332002	ROUND SUCTION FILTER FOR C95-1
350774	BRACKET
450106	CLAMP FE ZN 32-44 H=12,2
450115	ELASTIC CLAMP D.8,3/7,8
450137	COLLAR CONNECTION WITH BASE 31
450143	CLAMP D.39,7 X 37,7
450516	THERMOSTAT SHIELD FOR 2 TERMOS
460502	GASKET 30X21X2

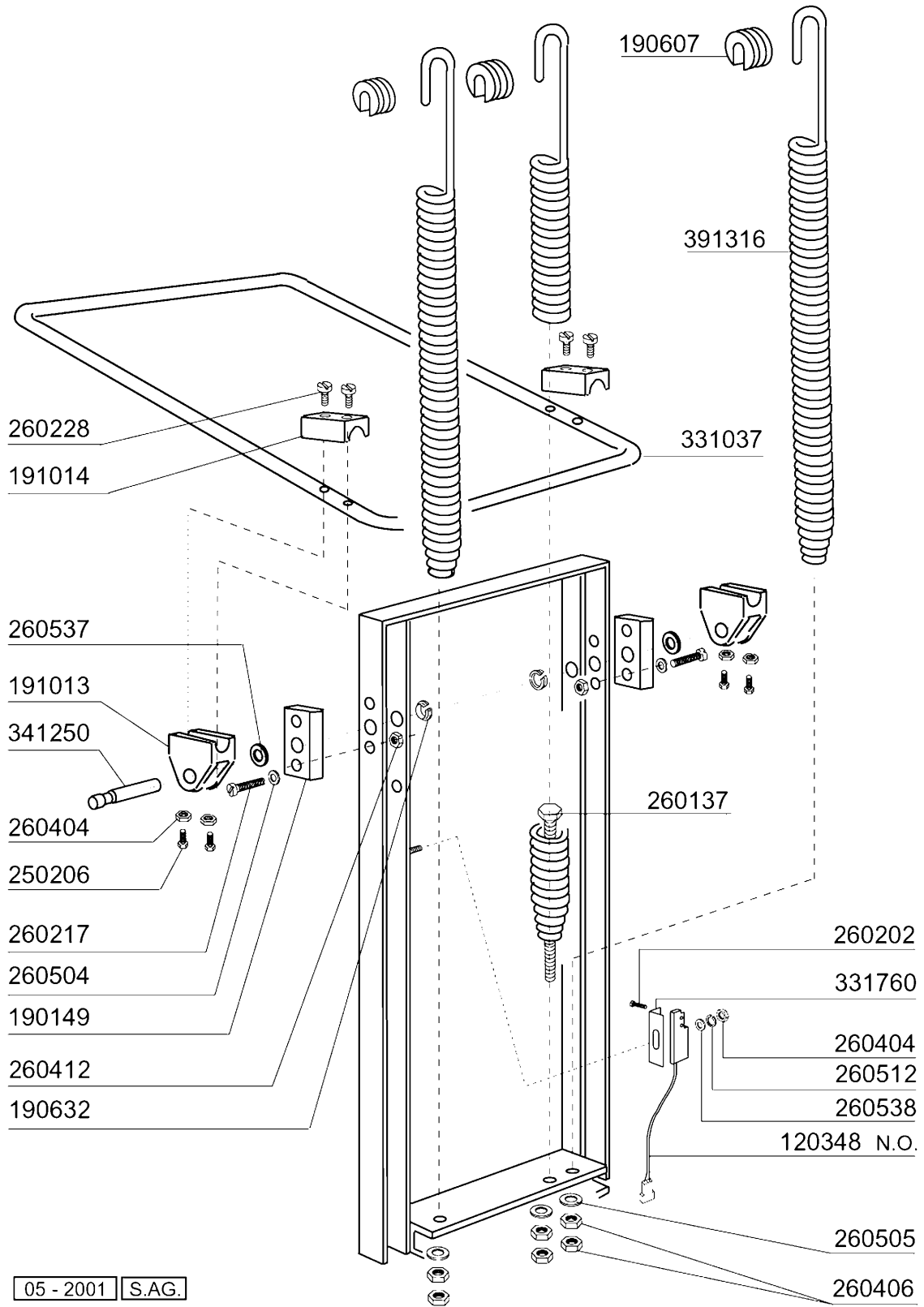

05 - 2001 S.A.G.

4 - Handle

CODE	DESCRIPTION
120348	MAGN.SWITCH (N.O.)
190149	REINFORCEMENT FOR HANDLE SUPP.
190607	HANDLE BUSH C30-70
190632	"NYLINER" BUSH
191013	HINGE F. SUPPORT C30-C70
191014	FLANGE F. HANDLE C30-70
250206	GRUB SCREW D.6
260137	SCREW TE 8X100
260202	SCREW TCP 3X16
260217	SCREW TCP 6X25
260228	STAINL.ST SPECIAL SCREW 6X42 3
260404	STAINLESS STEEL NUTS D6 UNI 55
260406	NUT 8MA
260412	SELF-LOCKING NUT M6
260504	ST/ST FLAT WASHER D6
260505	STAINL.STEEL FLAT WASHER D8
260512	ST/ST GROWER WASHER D6
260537	STAINL.STEEL FLAT WASHER D13X2
260538	WASHER 18X6X1,5 ST/ST
331037	HANDLE C95-155-165 ISOLATED
331760	BRACKET
341250	HANDLE PIN C85 C140
391316	SPRING FOR HANDLE C85/140-G75

5 - Wash/Rinse column

CODE	DESCRIPTION
160115	PL.TUBE.D.9.5 B41 (3/8) C30-
160804	GASKET D.6
180123	CONNECTION NUT / RINSE 5/8 C30
180240	FLANGE FOR PIPE ASSY. C95-C155
180413	TEE NIPPLE D.11,5 - RINSE ASSE
190309	CONNECTION STRAIGHT 3/8"B41C30
190315	ELL RINSE C30-70
190327	INLET FLANGE C95-C155-C165
191059	LOWER WASH ARM SUPPORT C95-155
200122	HOSE 11X19
200457	GASKET D.24X16X3 NEOPRENE
200768	DELIVERY HOSE "3 WAYS" C95-C15
200769	OUTLET HOSE C95-C155-C165
200803	OR GASKET 3,53X98,02X105,08
200820	O-RING151 46,99X5,33X57,6
200852	O-RING D.58,42X63,66X2,62
200853	O-RING D.63,5X70,56X3,53
200909	GASKET F.LOWER WASH ARM SUPP.C
260217	SCREW TCP 6X25
260404	STAINLESS STEEL NUTS D6 UNI 55
260512	ST/ST GROWER WASHER D6
270118	NUTS FOR ELBOW 5/8 C30-70
280118	ELL FF 3/8" - 1/4" C140-155
280522	NIPPLE FOR RINSE HOSE C95-C155
340499	SPINDLE CENTR. CROSS C34
341813	PUMP SUPPORT C95/155/165
341814	PUMP SUPPORT C95/155/165
420335	WASH COLUMN C95-C155-C165
441103	PUMP FEET
441111	PUMP FEET 25X25XM6
450103	CLAMP FE ZN. 13-20 H=9
450107	CLAMP FE ZN 38-50 H=12,2
450119	CLAMP FE ZN. 58-75 H=12,2
450127	CLAMP FE ZN. 68-85 H=12,2
460528	GASKET 15X10X2 FOR RINSE NIPPE

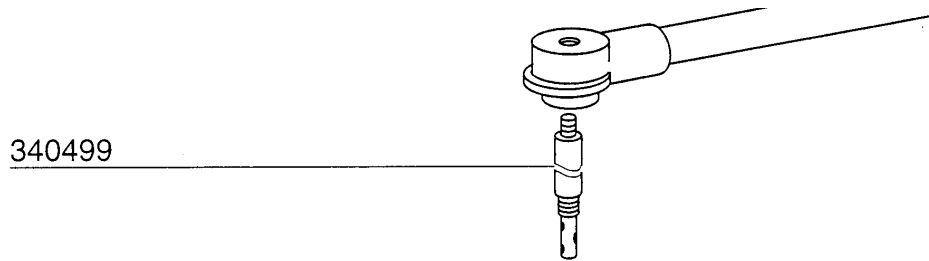

340499

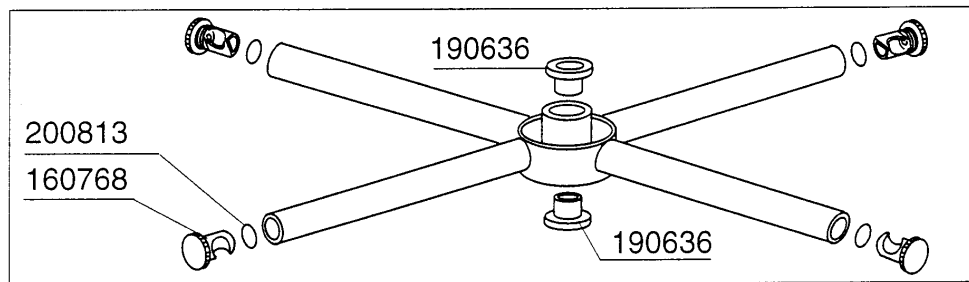

200813

160768

190636

190636

420535

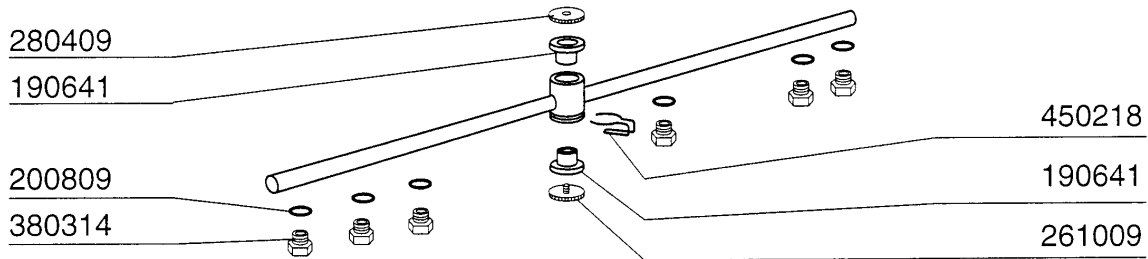

280409

190641

450218

200809

380314

190641

261009

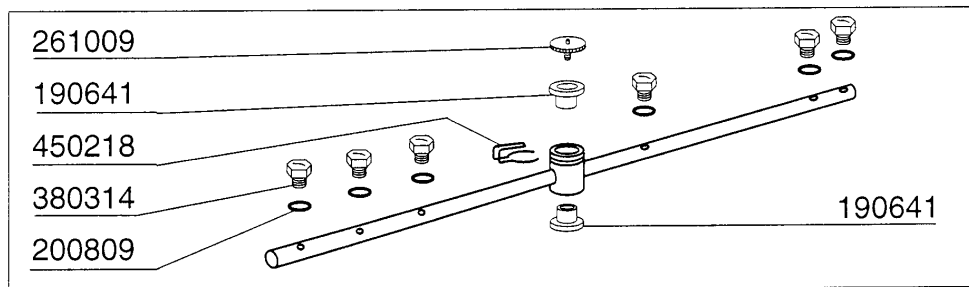

261009

190641

450218

380314

200809

190641

430316

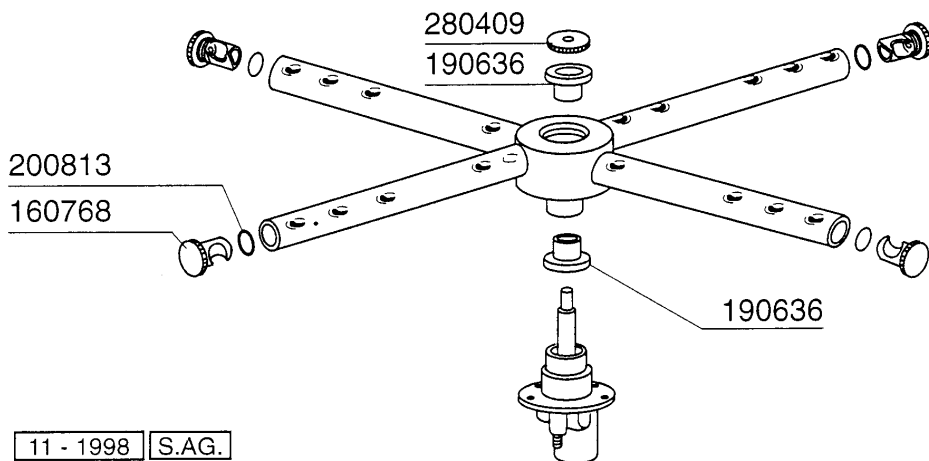

200813

160768

280409

190636

190636

11 - 1998 S.A.G.

6 - Wash arm

CODE	DESCRIPTION
160768	PLUG FOR "C95-155" WASH ARM
190636	BUSH FOR C95-155-165 WASH ARM
190641	BUSH FOR C95-155-165 RINSE ARM
200809	OR GASKET 1,78X8,73X12,29
200813	OR GASKET 2,21X16,36X20,78
261009	RETAIN.SCREW FOR WASH-RINSE AR
280409	RETAIN.LOCK NUT CENTR.CROSS C1
340499	SPINDLE CENTR. CROSS C34
380314	RINSE JETS 801/HR
420535	WASH ARM C1300-C155
430316	RINSE ARM FOR C95-C155-C165
450218	SPRING F.RINSE ARM RETAIN.SCRE

7 - Rinse assembly

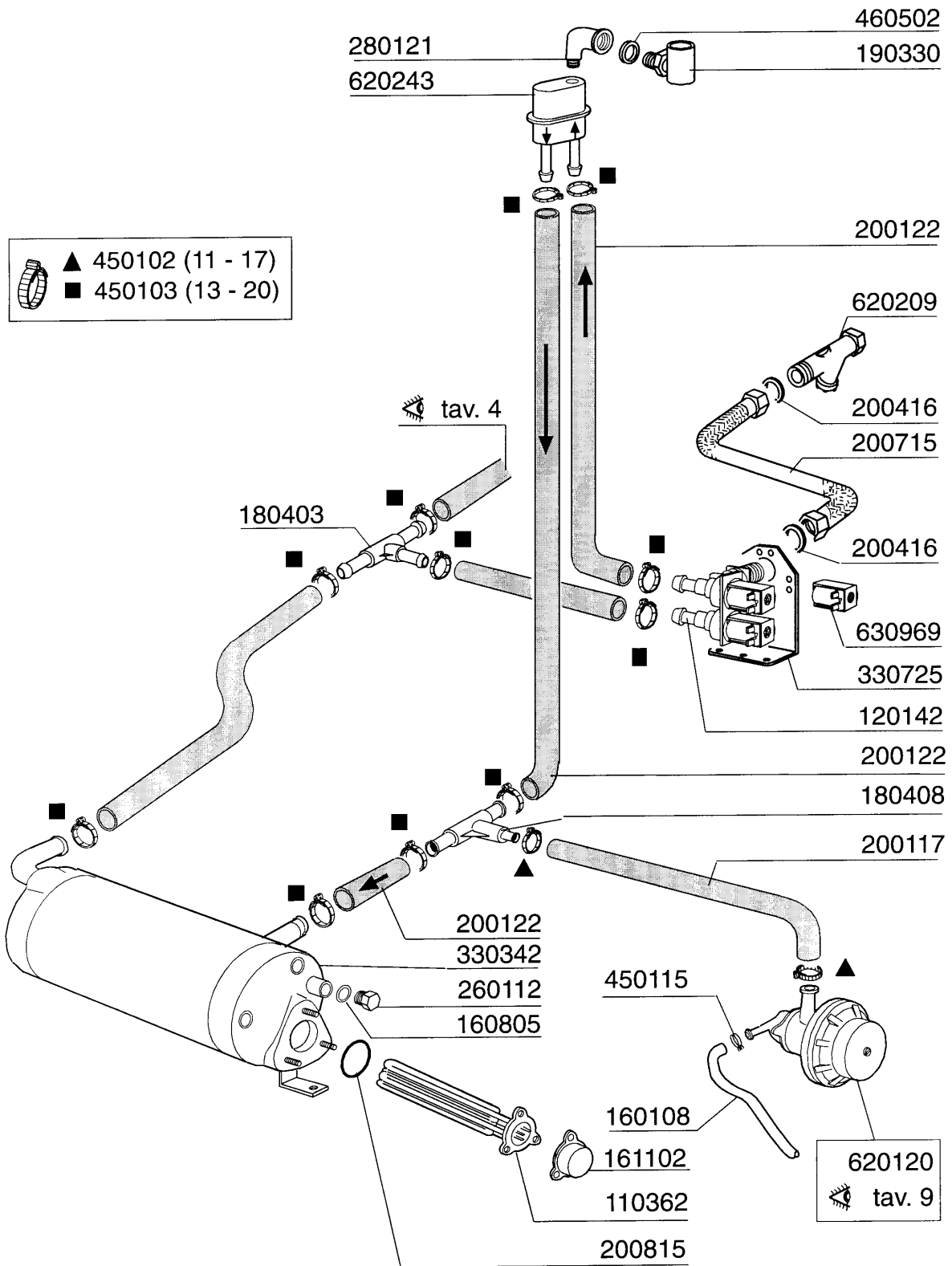

04 - 1999 S.A.G. 01

7 - Rinse assembly

CODE	DESCRIPTION
110362	HEAT.ELEMENT 9000W 220/380V
120142	SOLENOID VALVE 90Ø2WAYS 220V
160108	INJECT.INLET HOSE D.8X5
160805	GASKET D.8
161102	ELEMENT COVER MOPL.
180403	TEE-NIPPLE F2-F300-B10-11
180408	TEE-NIPPLE F.INJECT.W/CENTR.RE
190330	TEE FOR VAACUM BREAKER
200117	RUBBER HOSE 7X16
200122	HOSE 11X19
200416	GASKET D. 3/4"
200715	HOSE WATER INLET 2M STAINL.ST
200815	O-RING F. HEAT.ELEM.
260112	STAINLESS STEEL TE-SCREW 8X16
280121	ELL FOR VAACUM BREAKER
330342	BOILER C95-C155-C165
330725	STANDARD BRACKET F.SOLEN.VALV
450102	CLAMP FE ZN 11-17 H=9
450103	CLAMP FE ZN. 13-20 H=9
450115	ELASTIC CLAMP D.8,3/7,8
460502	GASKET 30X21X2
620120	RINSE AID INJECTOR
620209	INLET WATER FILTER
620243	VACUUM BREAKER (WITHOUT KIT)
630969	COIL S4216 220/50HZ

100716	220 - 240 - 380 - 415/3	50 Hz
100724	220 - 240 - 380 - 415/3	60 Hz
100726	220 - 240/1	50 Hz
100725	220 - 240/1	60 Hz

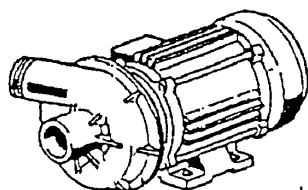

HP 2 - Kw 1,5 (1204)

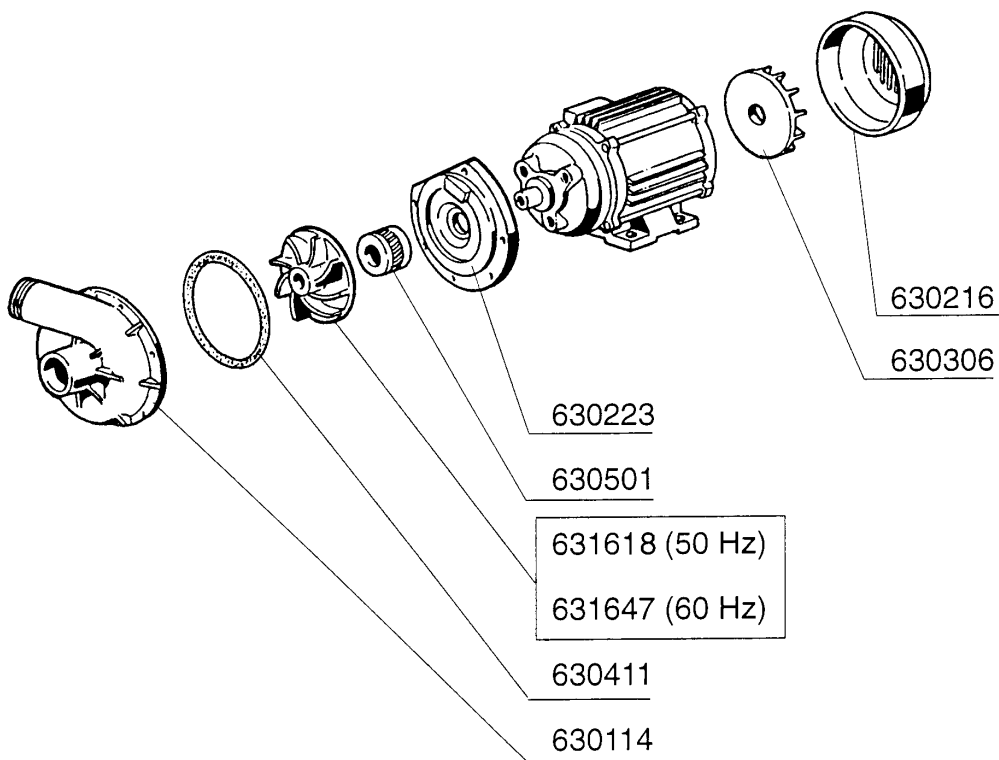

8 - Pump

CODE	DESCRIPTION
100716	PUMP 2HP 220/3-415/50-1204
100724	PUMP 2HP 230/400 60HZ 1204
100725	PUMP 2HP 230/1 60HZ 1204
100726	PUMP 2HP 220-240/1 50HZ 1204
630114	VOLUTE FI HP2-2,7-3-3,2
630216	FAN HOUSING FIR HP 2-3
630223	BACK PLATE PUMP HP2-3-3,2
630306	PUMP FAN IMPELLOR FI HP 2-3
630411	O-RING PUMP FI HP 2-2,7
630501	SEAL FOR PUMP HP 2-3-3,2
631618	IMPELLER PUMP F HP2-D.116,5
631647	IMPELLER D.100-60HZ-1204/5

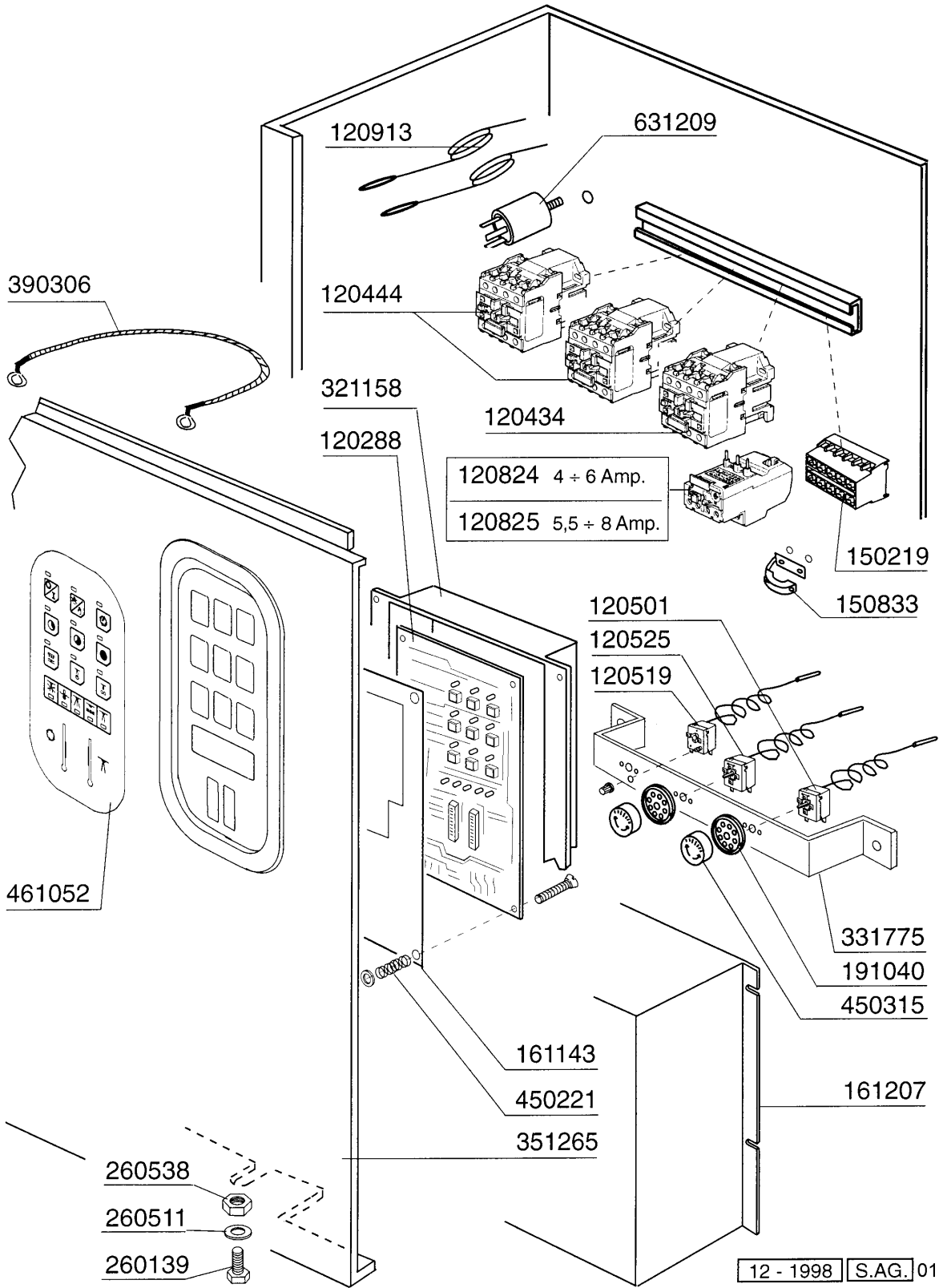

12 - 1998 S.A.G. 01

9 - Control Box

CODE	DESCRIPTION
120288	ELECTRONIC TIMER C165
120434	CONTACTOR 9A 220V 50HZ
120444	CONTACTOR 9A 220V 50HZ
120501	THERMOSTAT 30/90°C
120519	SECURITY THERMOSTAT 95-125°C
120525	BOOSTER THERMOSTAT 2 TEMPERAT.
120824	OVERLOAD RELAY 4/6 A
120825	OVERLOAD RELAY 5,5/8 A
120913	PROBE FOR FC+C PCB
150219	TERMINAL BLOCK 5P MMQ165VD26
150833	CABLE HOLDER BC/BR
161143	PROTECTION ELECT.CARD C165
161207	CONTROL BOX COVER FOR C95-155
191040	FRAME F.THERMOSTAT KNOB
260139	SCREW TE 5X16
260511	GROWER WASHER D.5
260538	WASHER 18X6X1,5 ST/ST
321158	COVER FOR ELECTRONIC CARD C165
331775	BRACKET 3 THERMOSTATS
351265	PANEL (351520)
390306	CABLE
450221	SPRING FOR ELECTRONIC TIMER
450315	KNOB F. THERMOSTAT 90°C
461052	PLATE C165
631209	ANTI-NOISE FILTER

10 - Rinse aid injector

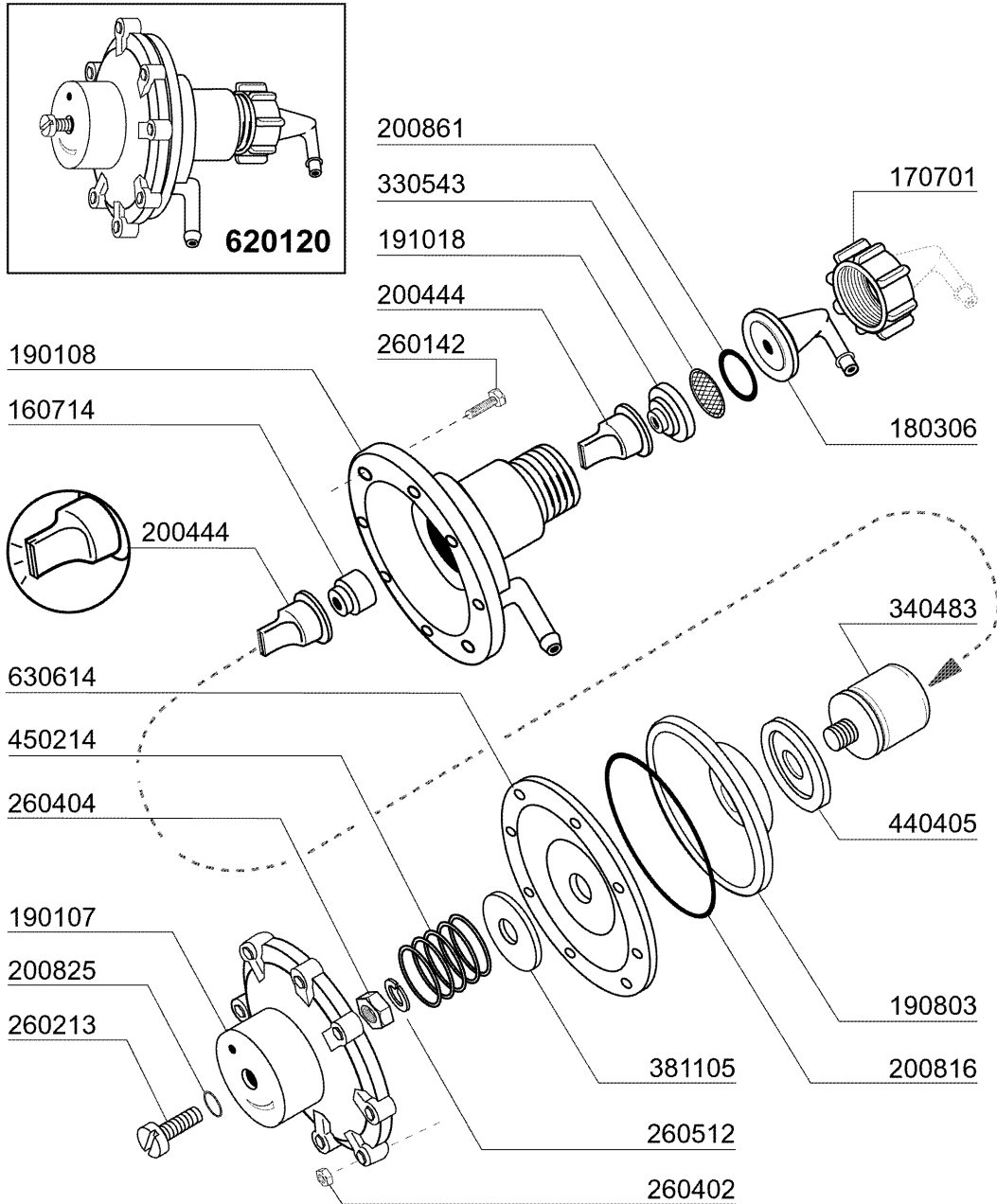

02 - 2004 | S. AG.

10 - Rinse aid injector

CODE	DESCRIPTION
160714	PLUG FOR RINSE AID INJECTOR MO
170701	LOCK NUT 1/2" F.INJECTOR
180306	NIPPLE F.RINSE AID INJECTOR
190107	COVER FOR RINSE AID DISPENSER
190108	VOLUTE FOR RINSE AID DISPENSER
190803	GASKET SUPPORT RING F.INJECT
191018	FILTER SUPPORT RINSE AID INJEC
200444	SUCTION VALVE RINSE INJECTOR
200816	O-RING 2,5X59,2X64,2 RINSE INJ
200825	O-RING 3X5X11 RINSE INJECTOR
200861	O-RING 14X18X2
260142	SCREW TE 4X16
260213	SCREW TCP 5X25
260402	STAINLESS STEEL NUT D4 UNI 55
260404	STAINLESS STEEL NUTS D6 UNI 55
260512	ST/ST GROWER WASHER D6
330543	FILTER RINSE AID INJECTOR D.17
340483	PISTON FOR RINSE AID DISPENSER
381105	DIAPHRAGME DISC
440405	GASKET FOR RINSE AID INJ.
450214	SPRING RINSE AID INJECTOR
620120	RINSE AID INJECTOR
630614	DIAPHRAGM RINSE INJECTOR